

Customer Switch - Mystic Tan

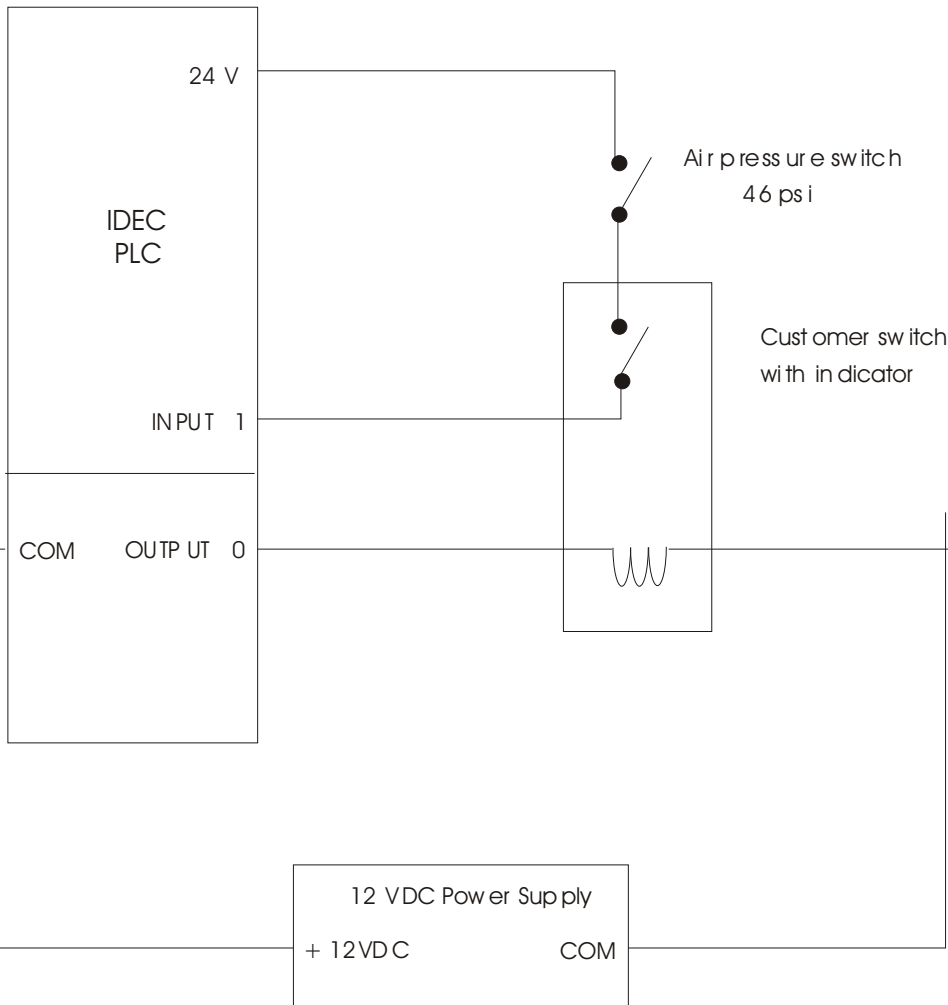

Pressure switch disables customer switch for air pressures below switch rating (46 psi). PLC input 1 will indicate a sensed closure of both air pressure switch and the customer switch. Once the PLC is enabled with Tanning level selection, a signal to input 1 will cause PLC to proceed to next step which is turning on the customer switch indicator. This is done with PLC output 0. On some models output 7 will also become active following an input 1. This output is not utilized.